

# Rocketry Handbook



**Version 1.2**



A training course for young rocketeers prepared by the  
**UK Rocketry Association**

Intentionally Blank

**WARNING**

**ROCKETS ARE NOT TOYS, THEY ARE  
MODELS. IF YOU MISUSE ROCKETS OR  
MOTORS YOU MAY INJURE YOURSELF OR  
OTHERS**

Intentionally Blank

## Contents

Rocketry Course Syllabus .....	6
Task 1 - Rocket Flight Profile .....	7
Task 2 - Parts of a Rocket .....	8
Task 3 - Parts of a Motor .....	9
Task 4 - Motor Codes .....	11
Task 5 - Stability .....	14
Task 6 - Safe Distances .....	16
Task 7 - Range Procedures.....	17
Task 8 - Swing Test (Practical Test).....	19
Task 9 - Pre-flight Inspection (Practical Test) .....	21
Task 10 - Preparation for flight (Practical Test) .....	22
Appendix 1 - Tips and Ideas .....	23
Appendix 2 - Flight Registration Card .....	24

# Rocketry Course Syllabus

This handbook contains the essential safety and technical knowledge required to fly model rockets. It has been prepared for use by youth leaders wishing to ensure a basic level of competence.

It has been written as a series of tasks. Each task should be mastered before moving on to the next one. Completion of task 7 will give enough knowledge to sit a multiple choice test. Papers and answers are available from the UKRA website. The pass mark is 60%.

Tasks 8, 9 and 10 are practical tests which must be supervised by an UKRA approved RSO. Satisfactory completion of the multiple choice test and the practical tests is required before cadets will be allowed to prepare and fly rockets.

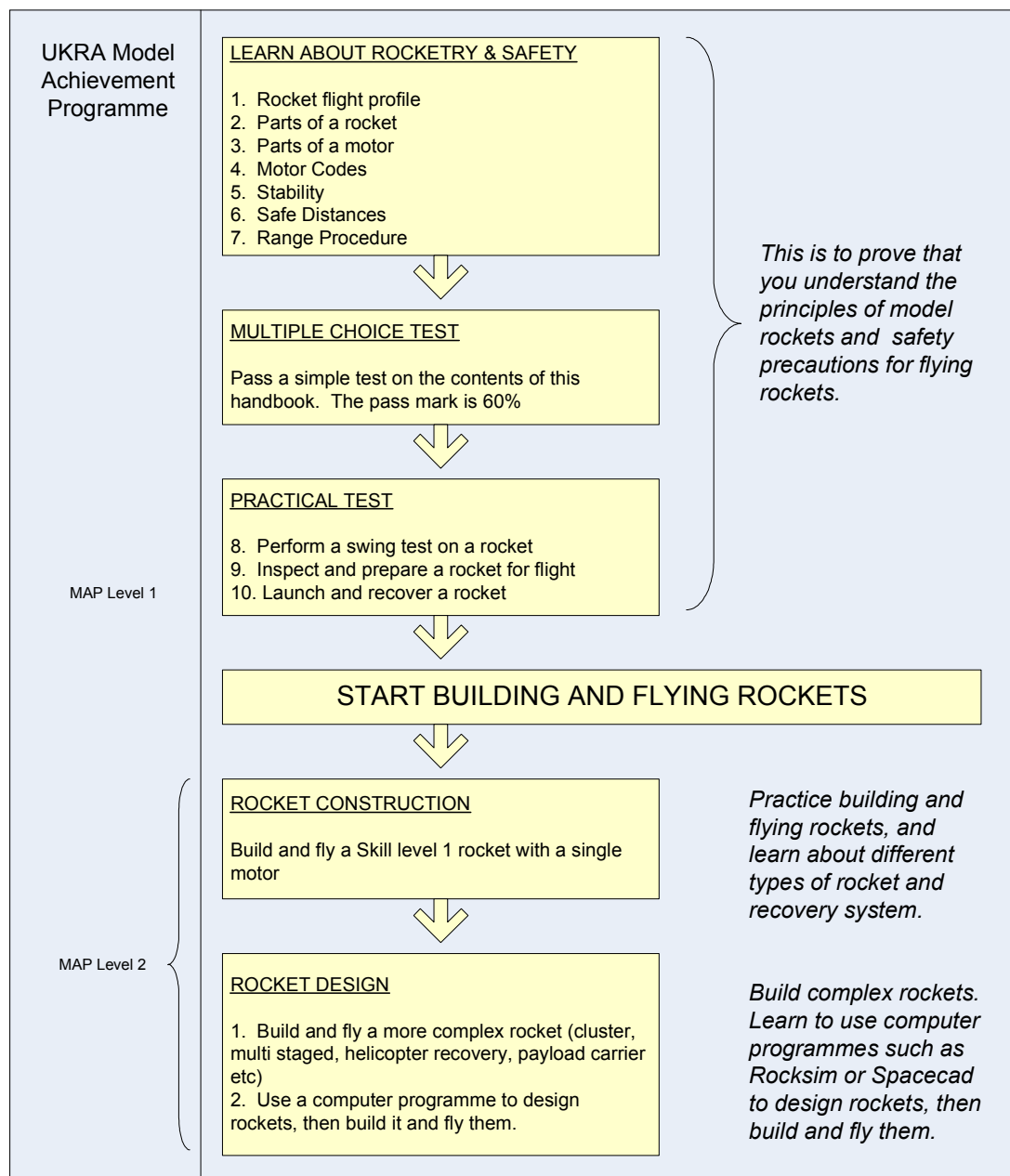

## Task 1 - Rocket Flight Profile

The picture shows the 5 stages of a rocket flight. After ignition the rocket accelerates vertically, then coasts to its highest point (apogee). At apogee a small charge deploys the parachute, allowing the rocket to float gently back to the ground.

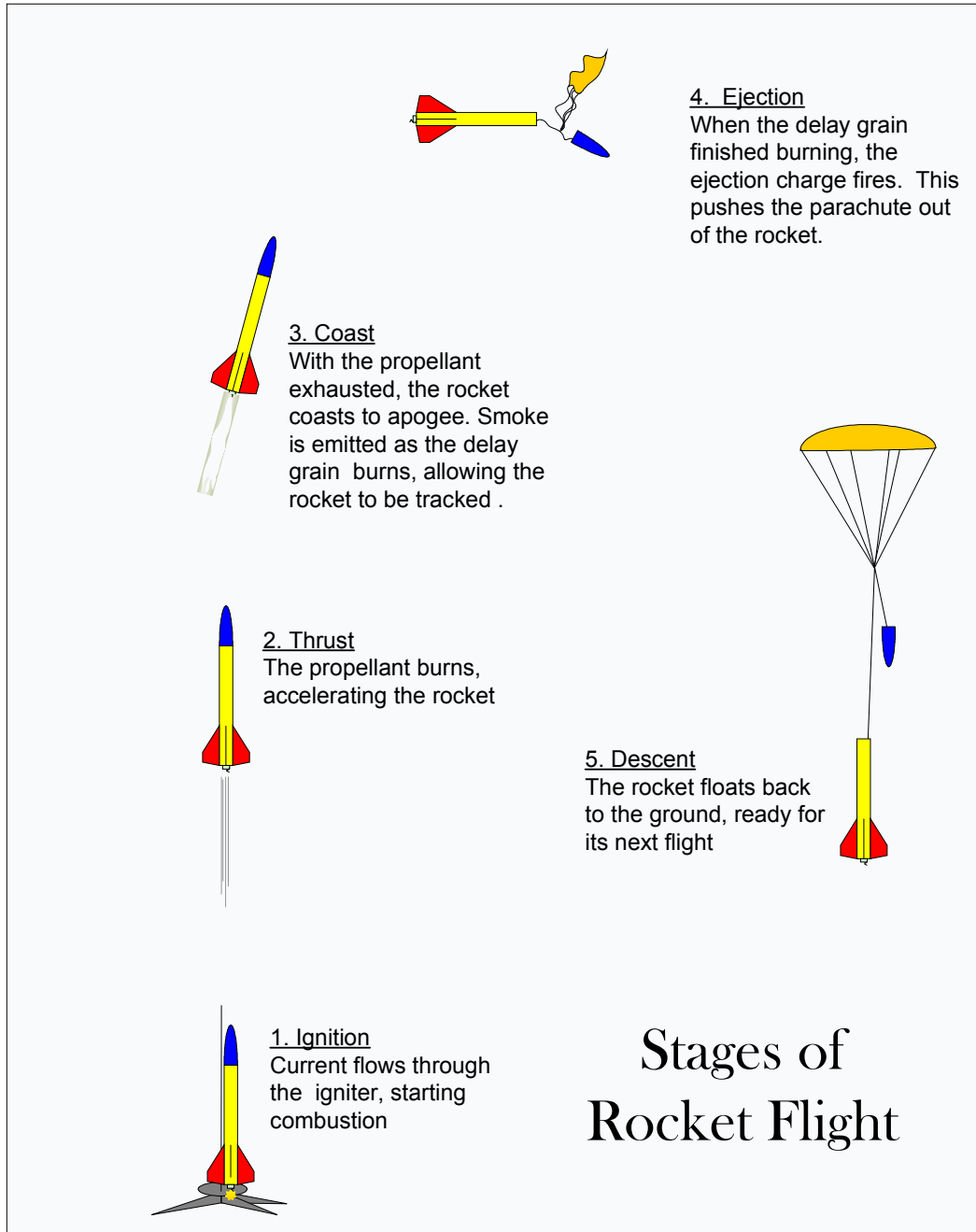

After landing, the rocket can be prepared again for another flight. You can get many flights out of a model rocket.

## Task 2 - Parts of a Rocket

The main parts of a rocket are shown below:

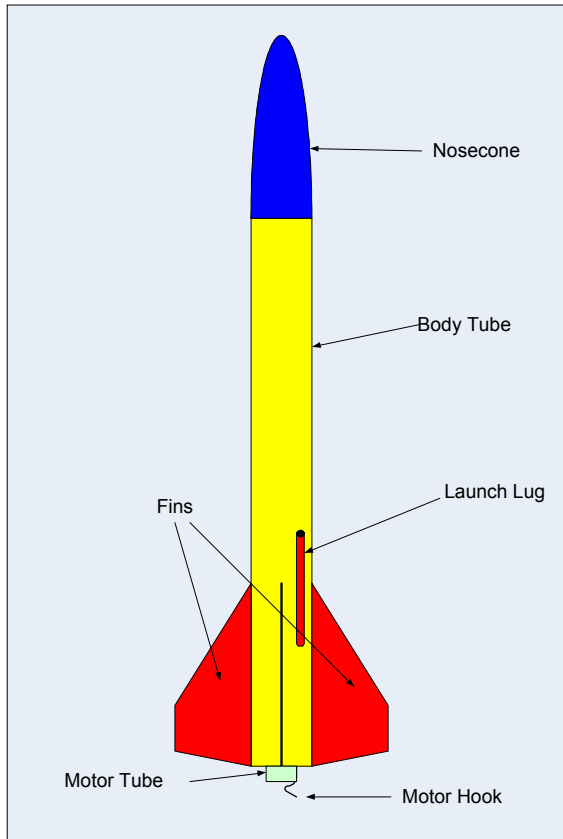

The **launch lug** attaches the rocket to the launch rod while it accelerates to aerodynamic flight.

**Fins** ensure that the rocket's flight is stable. The **parachute** is also attached to the shock cord.

The **nosecone** is aerodynamically shaped to minimise drag. It is loosely fitted into the **body tube**, and attached to the rocket body by the **shock cord**.

The motor is inserted into the **motor tube** where it is held in place by the **motor hook**.

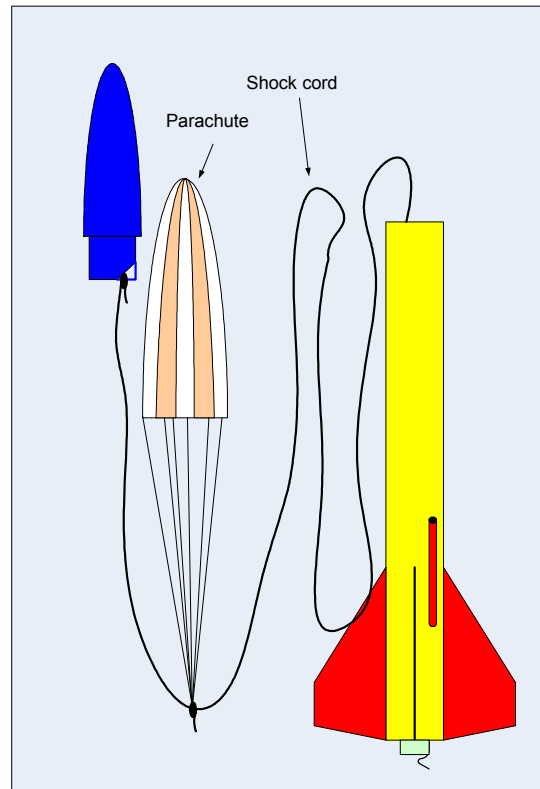



## Task 3 - Parts of a Motor

There are many types of motor. Understanding how motors work, and how to select the right motor, is very important. Using the right motor will reduce the number of crashes you have, and the number of rockets you lose.

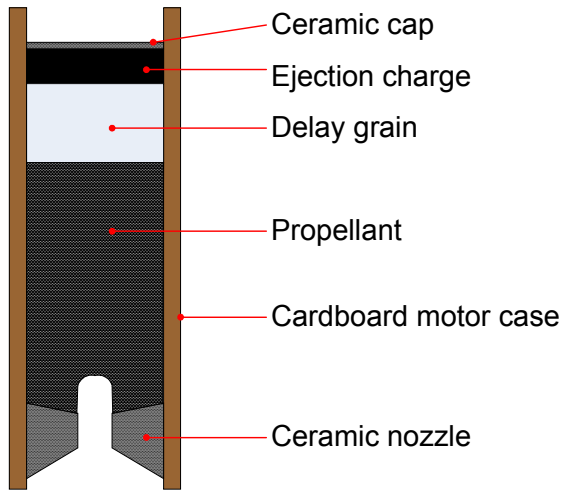

Parts of a motor

The picture shows a section through a motor. The motor case is made of a thick and dense cardboard as it has to contain the pressure of combustion. The ceramic nozzle is moulded into the motor.

The propellant is black powder, sometimes called "BP". The hot gas from the burning propellant is accelerated through the nozzle producing the motor's thrust.

When the propellant is all consumed it ignites the delay grain. This is a sulphur rich powder which burns slowly, releasing smoke so that the rocket can be tracked while it coasts.

When all the delay grain has been consumed it ignites the ejection charge. This small charge shatters the ceramic cap and pressurises the rocket, forcing off the nosecone and deploying the parachute.

**WARNING.** Rocket motors are expendable and bio-degradable - use them once and throw them away. Reloading is forbidden - it is dangerous.

## Parts of an Igniter

An igniter is a device used to ignite a rocket engine. In Estes rocket motors, an igniter element is a strip of resistance wire with a coating of pyrotechnic material on it.

The electric current from the launch controller flows through the igniter, the igniter begins to glow and give off heat. The pyrotechnic material, called the "pyrogen", is ignited and is the last step in the ignition.

Igniters must be installed so that the coating is touching the dark-coloured propellant grain. If the igniter is not touching the grain, this could cause a misfire.

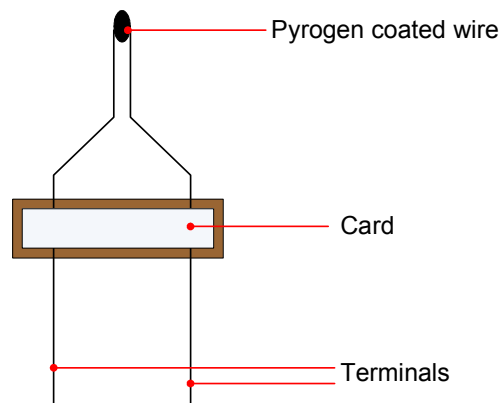

Parts of an igniter

## Launch Controller

The launch controller provides the power to set off the igniter. It is essentially a battery and a switch; however it is designed with safety in mind. A key switch, or similar device, isolates the battery. Unless the key is inserted and turned there will be no power to set off the igniter. Controlling the safety key is a simple way of preventing accidents on the range.

A diagram of a typical launch controller is shown below.

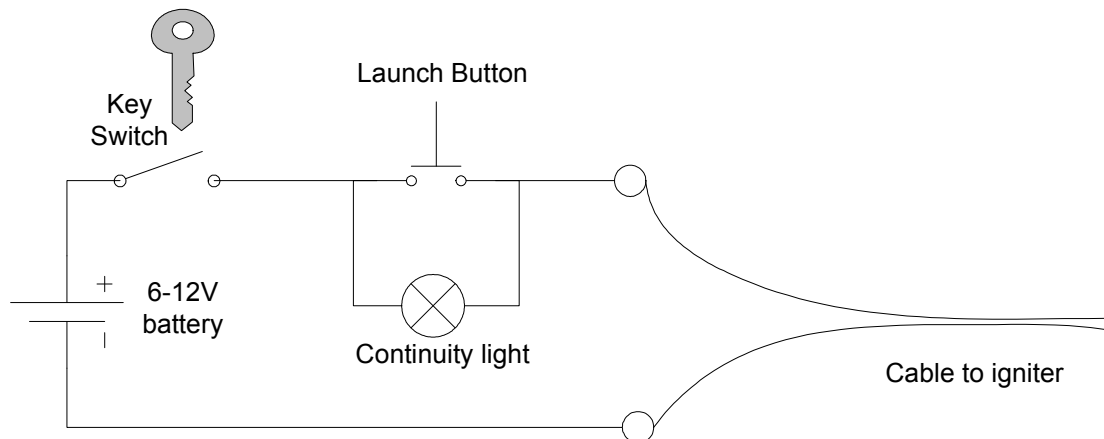

The key is inserted and turned just before starting the countdown. The continuity light will light up if there is a good circuit to the igniter. The current through the bulb will not be enough to fire the igniter. On completing the countdown, the launch button is pressed. The current flows straight from the battery to the igniter, and within a second the motor will ignite.

**Tip:** The batteries in launch controllers which come with rocketry "starter kits" don't last long. It's worth making a group launch controller with rechargeable batteries. The 12V lead acid gel batteries are ideal. Don't forget the safety key. It must isolate the battery when the key is withdrawn.

## Task 4 - Motor Codes

There are many different motors available for model rockets with codes like A8-3, C6-7 and  $\frac{1}{2}$ A-3T. Choosing a motor with the right code will make the difference between a good flight, a crash, or a lost rocket. This section explains motor codes so you know which motor to select.

### How motors work

The motor burns in four stages:

1. Ignition - a current through the igniter sets off the pyrogen and ignites the propellant.
2. Thrust phase - the propellant burns, accelerating the rocket to its maximum velocity.
3. Coasting phase - the motor burns a smoke-emitting delay charge as it coasts to apogee.
4. Ejection phase - a small charge blows the nose off the rocket and deploys the parachute.

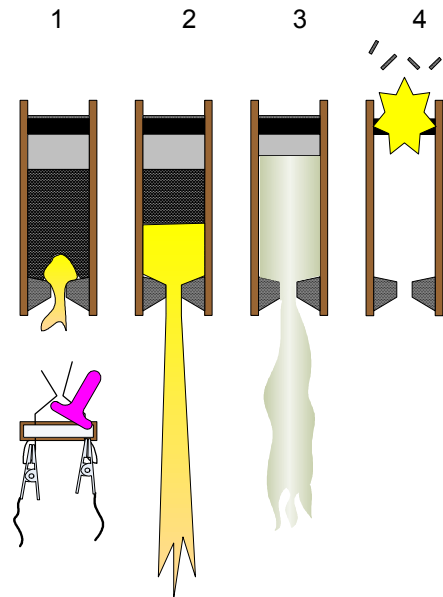

The first thing to understand is the thrust time curve. This shows the amount of thrust a motor gives as the propellant burns.

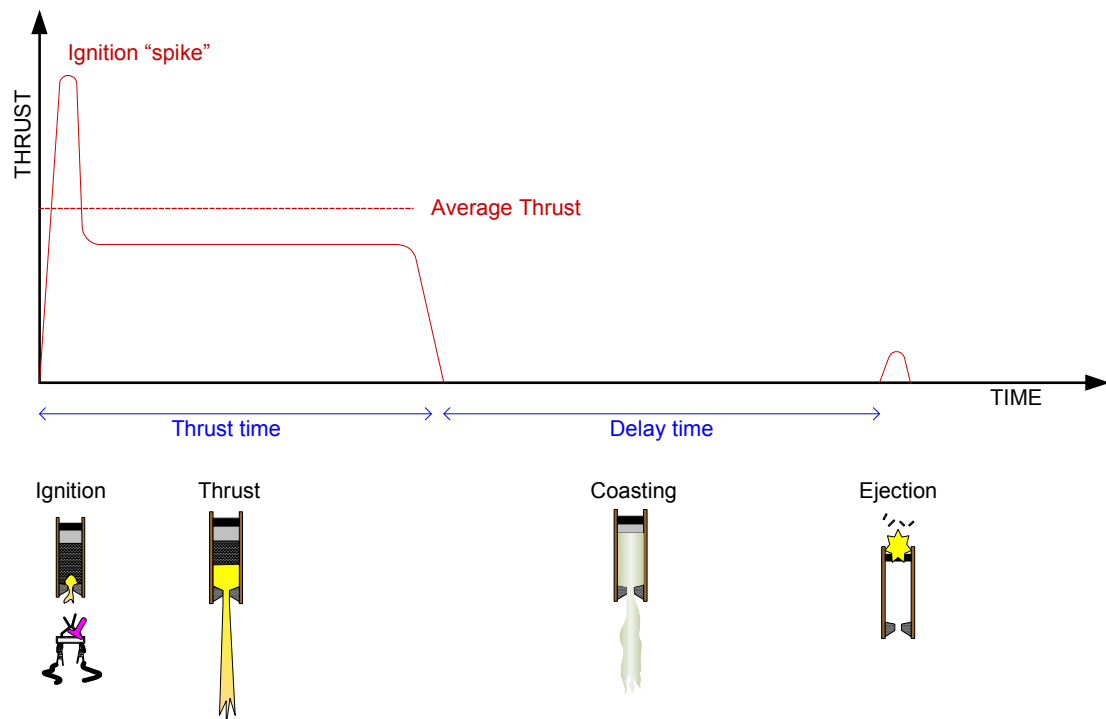

When the motor ignites it gives a short "spike" of thrust. This helps to get the rocket started up the launch rod. The motor then burns its propellant until all the propellant is

consumed. The rocket then coasts while the delay grain burns and emits tracking smoke. The ejection charge is fired when all the delay grain has been consumed.

We specify motors by three factors:

1. the average thrust which they produce
2. the time for which they produce that thrust
3. the delay before the ejection charge is fired.

Clearly 1 and 2 are related. The same amount of propellant can be burned quickly to produce high thrust for a short time, or slowly to produce a small amount of thrust for a long time. The combination of thrust and time is called the **IMPULSE** of the motor. More scientifically:

$$\text{impulse} = \text{average thrust} \times \text{burn duration.}$$

As thrust is measured in Newtons, and time is measured in seconds, then impulse is measured in Newton-seconds. The impulse is thus directly related to the amount of propellant. The more propellant, the greater the impulse of the motor.

Using all this information, we can now start to understand the motor code. The first letter (A, B, C etc) tells us the impulse of the motor, the first number tells us the average thrust, and the second number tells us the delay before the ejection charge is fired.

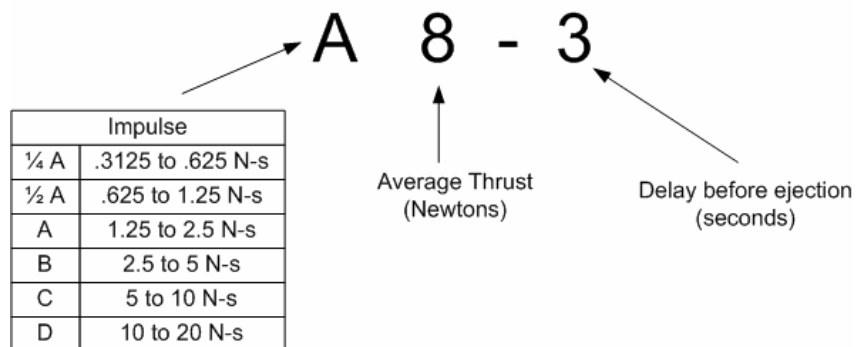

**Example:** What does the motor code C6-7 mean?

**Answer:** The motor is has an impulse of between 5 and 10 Newton-seconds, has an average thrust of 6 Newtons, and will fire the ejection charge 7 seconds after the motor burns out.

There are many motors available through model shops and specialist suppliers in the UK. The most common motors are:

Motor	Delays (seconds)	Diameter
½ A	2, 4	13mm
A10	3	13mm
A8	3, 5	18mm
B4	2, 4	18mm
B6	0, 2, 4	18mm
C6	0, 3, 5, 7	18mm
D12	0, 3, 5, 7	24mm

## Thrust & Rocket Weight

The average thrust must always be greater than the weight of the rocket. For a safe flight the thrust must be at least 5 times the weight of the rocket at launch. The weight of the rocket is measured in Newtons, not Kilograms. To calculate the rocket's weight in Newtons multiply its mass in kg by the acceleration due to gravity.

The acceleration due to gravity is 9.81 m/s/s. This is a difficult number to multiply anything by, so we tend to call it 10 m/s/s.

*Example: A rocket with a C6 motor weighs 160gm at launch. Is it safe?*

*Answer: The weight of the rocket is 0.16kg, which is 1.6 Newtons. The C6 motor has a thrust of 6 Newtons. The thrust to weight ratio is  $6/1.6 = 3.75$ . This is less than 5, so the rocket should not be launched.*

## Delay

Selecting a motor with the correct delay can make a big difference. If a rocket is expected to coast for 5 seconds then a motor with a delay of 5 seconds must be used. If the delay is too short the ejection charge will deploy the parachute while the rocket is still coasting. Similarly too long a delay will deploy the parachute while the rocket is descending. Deploying parachutes while the rocket is travelling at speed is a good way of damaging or destroying it.

The most popular motors for model rockets are the A8-3, B6-4, C6-5 and D12-5. The delay for these motors is suited to a typical rocket. What if a rocket is not typical, or the conditions are not ideal? Some useful rules of thumb to remember:

1. Fat rockets fly lower, so reduce the delay
2. The bottom stage of a two stage rocket has zero delay
3. The top stage of a two stage rocket has a long delay
4. When it's a bit windy you should shorten the delay

## Task 5 - Stability

Real rockets use complex electronic control systems to help them fly in a straight line. Model rockets use the air flow over the fins to control their direction.

Imagine a rocket moving through the still air. If the rocket is travelling in a straight line the air flows smoothly over the model.

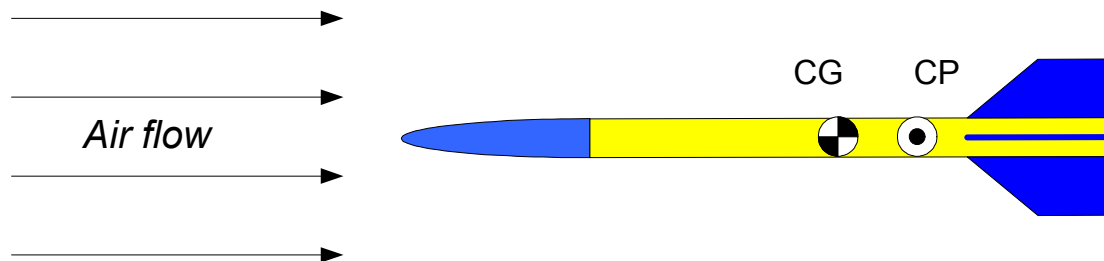

If the model's flight is disturbed it will rotate by a small angle to the airflow. This angle, shown as "a" in the diagram below, is called the "angle of attack". The flow of the air over the fins generates lift, which tries to restore the rocket to normal flight. A well designed rocket will quickly return to normal flight. Such a rocket is said to be stable.

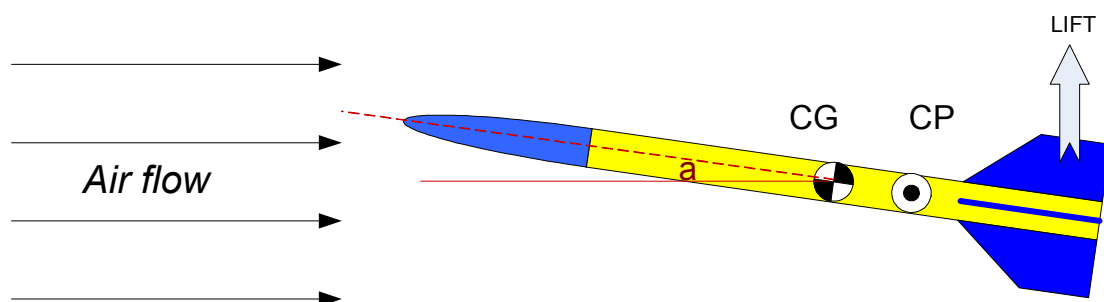



If the rocket continues to fly in the new direction, or flies in random directions, it is said to be unstable.

You'll have noticed that the diagrams show two symbols, *CG* and *CP*. The centre of gravity (*CG*) is the point of balance of the rocket. When the rocket is packed for flight it will balance at the *CG*. The centre of pressure (*CP*) is the point through which, such as lift and drag, and all the other aerodynamic forces, will act.

The relative positions of *CP* and *CG* on a model decide whether it is stable or unstable. The rule is that the *CG* must always be one or two body diameters in front of the *CP* for a stable rocket. If the rocket has several different diameters then the largest body diameter is always chosen.

**Tip:** The *CP* and *CG* are usually shown by the following symbols:

-  This symbol is always used to show the centre of gravity (*CG*)
-  This symbol is always used to show the centre of pressure. (*CP*)

It is usually possible to judge whether a rocket is likely to be stable or unstable by looking at the diameter and position of the fins. A rocket with a single set of sizeable fins at the tail is likely to be stable. If these fins are too small the rocket will become

marginally stable. If the fins are too small, or the rocket has additional fins at the nose (often the case with scale models of missiles) then the rocket will become unstable.

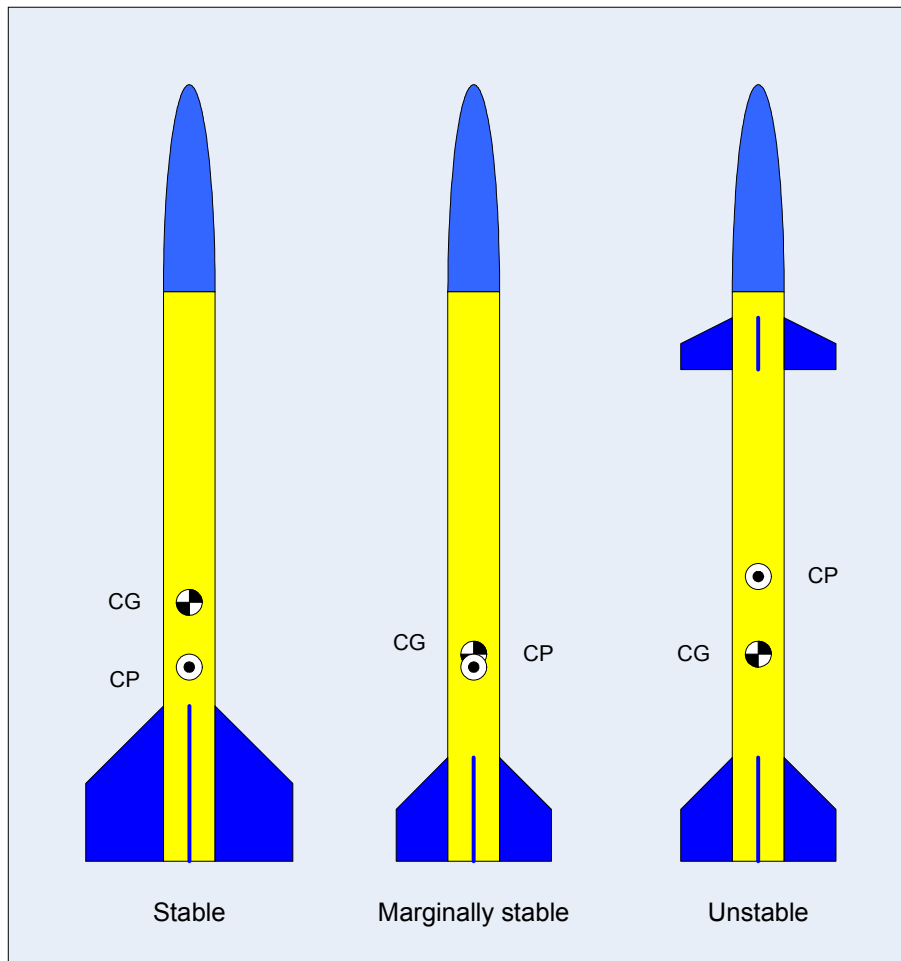

Two things can be done to improve the stability of a rocket. Firstly, the size or number of fins at the tail can be increased. This will move the centre of pressure back towards the tail. The second way to improve stability is to add some weight to the nose. This will move the centre of gravity forwards.

Many scale model kits contain modelling clay which has to be packed into the nose to move the CG forwards. Other materials such as blue-tack, or lead shot mixed into epoxy cement, are just as effective.

## Task 6 - Safe Distances

Sometimes launches go wrong, so it is good practice to be a safe distance away from the rocket. How far is safe enough? The UKRA safety code says that the minimum distance from a rocket depends on the impulse of the motor. These safe distances are:

Motor Impulse	Safe Distance (Rockets with single motors)	Safe Distance (Rockets with multiple motors)
$\frac{1}{4}A$ $\frac{1}{2}A$	2 meters	3 meters
A	2 meters	3 meters
B	3 meters	6 meters
C	3 meters	6 meters
D	5 meters	10 meters

Note that these are the minimum distances. It is always a good idea to be as far away as practical. In the ATC you must always be at least 10 meters away from your rocket before launching it, regardless of its impulse. All spectators must be further away.

*Tip: When you make your launch controller put at least 12m of cable on it. This allows for a bit of slack at both ends. As the cable gets burned away you can simply cut a few cm off the end and attach the crocodile clips to the new bit.*

Rockets will drift on their parachutes. The bigger the motor the higher the rocket will go, and the higher it goes the further it will drift. The UKRA safety code requires minimum site dimensions for launch sites. The size depends on the maximum impulse of motor to be flown from that site.

Motor Impulse	Minimum site dimensions
$\frac{1}{4}A$ $\frac{1}{2}A$	15 x 15 meters
A	30 x 30 meters
B	60 x 60 meters
C	120 x 120 meters
D	150x 150 meters

The sides of the site must also be at least equal to the maximum altitude that the rocket will reach.

*Example: A rocket with a C impulse motor is expected to fly to an altitude of 250 meters. What is the minimum site size?*

*Answer: from the table C impulse motors require a site 120 x 120 m, whereas the expected altitude of 250 m requires a site 250 x 250m. the site must be the larger of the 2 dimensions, so the site must be at least 250 x 250m.*



# Task 7 - Range Procedures

## The RSO

A launch area is called a "range". Safety on the range is controlled by the RANGE SAFETY OFFICER (RSO). RSO's are experienced rocketeers who have passed an exam and an interview to prove their ability to run ranges. The RSO is to be obeyed at all times.

## Range Layout

Rocket ranges should be laid out with safety in mind. The following range layout is based on that used by clubs and at UKRA events.

The launch pads are laid out in a line, and identified by a board with an identifying letter or number. The cables are laid out parallel to each other to a launch point. For flying up to impulse "D" motors no one must be closer than 10m to any launch pad, so the cables must all be over 10m long.

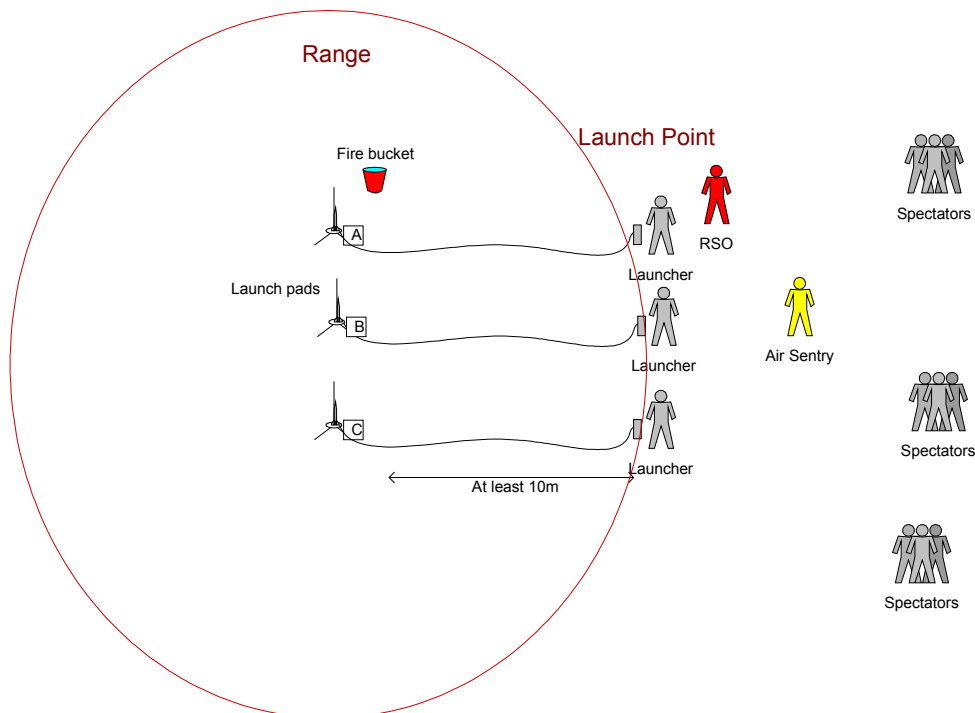

The RSO is positioned immediately behind the launchers so that he has a clear view of the range. An air sentry may be posted on a busy range, assisting the RSO to keep an eye out for any aircraft. The air sentry is located within earshot of the RSO and at a point where he has a clear view of the airspace around the launch site. Spectators are positioned well behind the launchers and RSO.

## Range Procedure

At the start of each flying session the RSO will call "RANGE OPEN". Anyone wishing to launch may then collect a motor from a member of staff and prepare their rocket for flight. Once it is ready you should fill out the flight card and present the card and rocket to the RSO for inspection.

The rocket must be inspected and approved by the RSO before it can be put on the launch pad. If it is the first time a rocket has flown, or if it has been modified since the last flight, the RSO may ask you to do a swing test to prove its stability.

Once the RSO clears the rocket it can be put on the launch pad. On arrival at the pad you will remove the safety cap from the launch rod, place your rocket on the rod, and connect the igniters to the launch controller. **DO NOT INSERT THE SAFETY KEY.**

Once all rockets are ready the RSO will call **"RANGE CLOSED"**, and everyone must vacate the range.

## **Countdown & launch**

Once the RSO gives permission to launch your rocket you may insert the safety key. You will give a loud countdown "5 - 4 - 3 - 2 - 1 - LAUNCH". and press the "launch" button.

If anyone calls "HOLD" you must stop your countdown, remove the safety key, and wait until the RSO gives you permission to resume.

## **Misfires**

If the rocket misfires (fails to launch):

- Remove the safety key.
- Wait for **one minute** in case the motor is smouldering.
- After one minute approach the rocket with the RSO.
- Try to identify the problem, often its just wires or a broken igniter.
- Return to the launch point and follow the RSO's instructions.

## **Descents**

Sometimes flights don't go according to plan, for example the parachute fails to deploy or the rocket drifts near to some people. When a rocket looks as if it might hit someone people will shout "HEADS UP". This means look up quickly to see if the rocket is coming down near you and, if it is, then be prepared to move out the rocket's path.

If you see a rocket descending near someone you should shout "HEADS UP".

## **Recovering your rocket**

Watch the rocket go, and make a note of the point where it lands. Do not run straight after your rocket but wait until all rockets have landed. Once the RSO calls "RANGE OPEN" you may go and retrieve your rocket.

Do not go through the range to retrieve your rocket, walk around it. There may be rockets "hung up" which require attention, or people preparing their rockets for launch.

If your rocket lands somewhere dangerous, such as draped over power lines, then forget it. No rocket is worth risking your life. You can always build another.

Do not run after your rocket, you may trip or fall.

## Task 8 - Swing Test (Practical Test)

An unstable rocket is not safe. It will fly randomly around the sky and eventually crash into someone or something. But how do you know if a rocket is stable?

The stability of the rocket should be tested at the following times:

- Before its first flight
- after any repairs or modifications
- when the RSO requires it

The simplest method of testing stability is called a **SWING TEST**. This ensures that the rocket will fly straight up, and will not tumble.

A swing test is always performed with the rocket packed for flight with a motor, wadding and recovery device.

To perform a swing test attach a loop of string around the rocket's point of balance. The rocket should hang horizontally, as shown below. Tape the string in place with some removable tape.

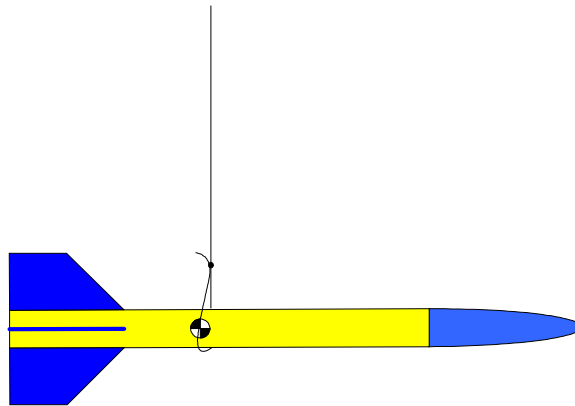

The rocket is then swung around your head on the string. Gradually play out the string until it is about 2-3m (6-10 ft) long. The rocket should fly nose first. If it doesn't then the rocket is unstable and must not be launched.

The picture below shows how the rocket should look on a swing test.

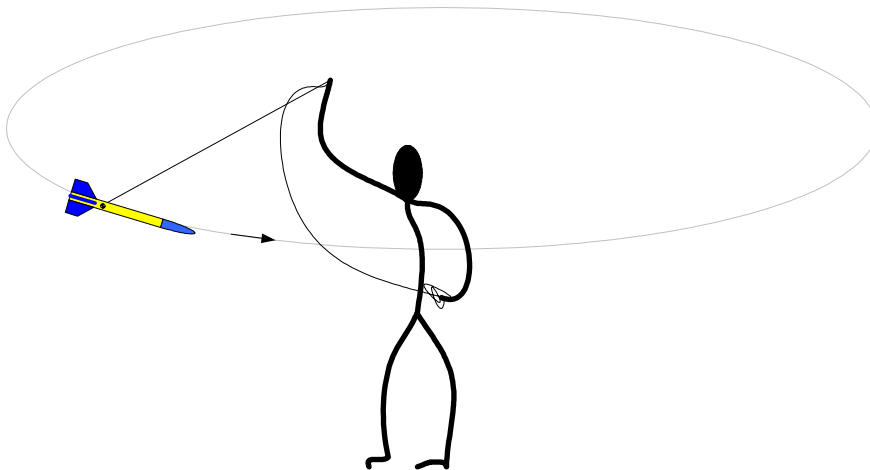

If the rocket is unstable it will not point into the wind but will fly backwards, or tumble.  
A rocket which fails a swing test must not be flown.

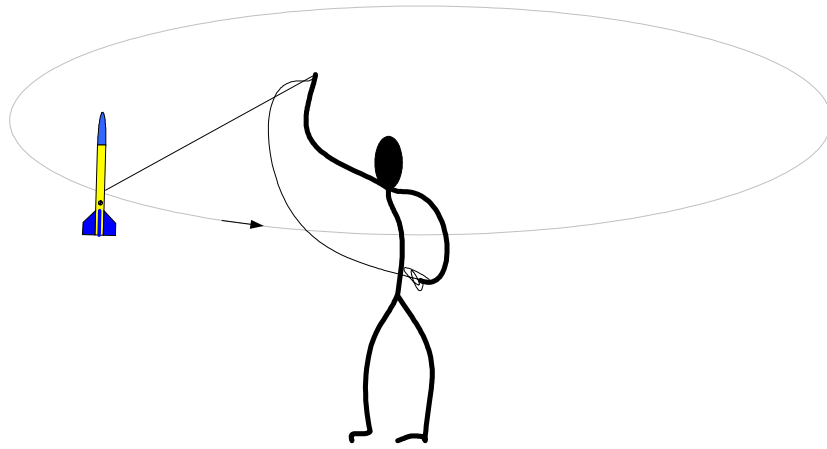

## Task 9 - Pre-flight Inspection (Practical Test)

Before every flight the rocket should be inspected to check the following:

1. Is there any damage to the body that might cause it to fail in flight?
  - a. Look for obvious damage
2. Is the parachute firmly attached?
  - a. Look at the shroud lines - are they attached to the shock cord.
3. Is the parachute free from damage?
  - a. Look for torn attachments, signs of melting.
4. Is the shock cord undamaged ?
  - a. Give it a tug
5. Is the nosecone fitted too tightly to be ejected?
6. Are the fins secure and aligned correctly?
  - a. Wobble each fin and see if it moves.
  - b. Look for cracks in the fin or the glue.
7. Is the motor retaining clip OK?

If the rocket fails any of these tests then it must not fly until it has been repaired.

## Task 10 - Preparation for flight (Practical Test)

Follow this simple sequence to prepare your rocket for flight:

### Inspection

Inspect the rocket for damage, as describe in task 9.

### Motor and wadding

1. Obtain a motor, igniter and plug
2. Insert the motor in the rocket
3. Insert recovery wadding (refer to the instructions for the correct amount).
4. Fold and insert the recovery device.

### Flight Card

Fill out a flight card and take the rocket to the RSO for inspection. If the RSO approves the flight you can put it on a launch pad next time the range is open.

### Launch Pad

Remove the cap and slide the rocket onto the launch rod. It should slide smoothly down to the bottom without being forced. If it does not slide easily then ask the RSO for assistance.

### Inserting the Igniter

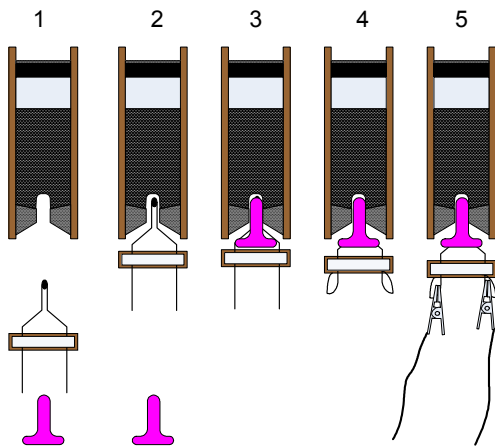

1. Check that you have an igniter and plug (make sure the plug's the correct colour).
2. Install the igniter so that it is touching the propellant
3. Insert the plug, taking care that the wires don't touch each other.
4. Bend the igniter leads back over the card.
5. Clip the crocodile clips onto the wires and give them a pinch

### Launch

When the RSO gives you permission to launch your rocket you may insert the safety key. You will give a loud countdown "5 - 4 - 3 - 2 - 1 - LAUNCH" and press the "launch" button.

## Appendix 1 - Tips and Ideas

### **So you want to learn more about rocketry....**

1. Get a copy of "Model Rocketry" by G Harry Stine or "The Model Rocketry Handbook" by Stuart Lodge. These are great books for starting out in model rocketry and contain advice built on many years of experience.
2. Read and raid the Estes Educator website for the incredible amount of free posters, handbooks and ideas that it offers. <http://www.esteseducator.com/>

### **Making advanced models ....**

3. When you want to develop beyond building kits get a copy of "Model Rocket Design and Construction" by Tim Van Milligan. It's packed with detailed ideas for design and construction of all sorts of rockets.
4. Also get a copy of one of the good simulation programmes like Rocksim or SpaceCad. It will take a lot of trial and error out of projects.

### **Some tips for more enjoyable flying....**

5. When looking for your rocket, mark a point beyond where the rocket fell and walk towards it.
6. Put low impulse motors in small rockets - it's no great achievement to lose one because it flies out of sight.
7. Paint a small rocket in bright colours so it will show up in the grass.
8. Make your own parachutes from poly bags and cotton thread, it's a lot cheaper than buying them.
9. Find your local kite maker as they always have offcuts of ripstop nylon. It's great material for making streamers.

### **Some ideas for rocket projects....**

10. Design and build a rocket which uses a "cluster" of two or more motors.
11. Design and build a group launch controller with rechargeable batteries. This will save a lot of money in batteries.
12. Two stage rockets reach higher altitudes than single stage rockets. Learn how two-stage rockets work, then design and build one.
13. Build a rocket which can carry a raw egg and keep it airborne for as long as possible.
14. How long can you keep your rocket airborne? Challenge another squadron to a "parachute duration" competition. This needs lots of space!
15. Try to build an exact scale model of a real missile or rocket.

## Appendix 2 - Flight Registration Card

This card may be used for 3 flights. Copy it and use it for your flights.

Name	Site	Date
------	------	------

Rocket Name	Number of Stages	Kit or Scratch Built	Recovery System
Mass at launch	Thrust at launch	Number of Motors	Total Impulse
Comments		RSO Signature	

Rocket Name	Number of Stages	Kit or Scratch Built	Recovery System
Mass at launch	Thrust at launch	Number of Motors	Total Impulse
Comments		RSO Signature	

Rocket Name	Number of Stages	Kit or Scratch Built	Recovery System
Mass at launch	Thrust at launch	Number of Motors	Total Impulse
Comments		RSO Signature	